

Update : 2015/10/13

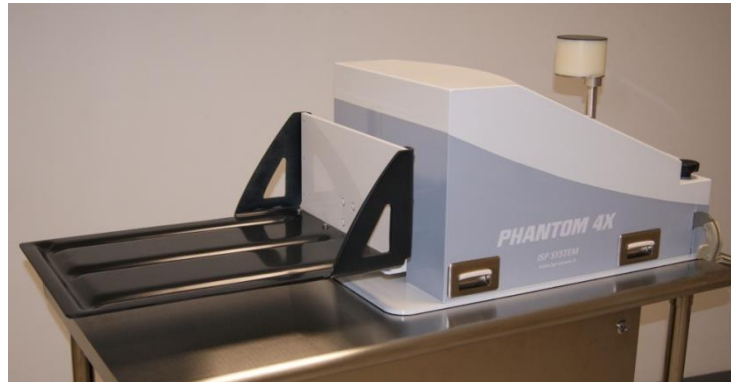

Non contractual photo

This device moves a Phantom for imaging devices according to a customizable 3D trajectory.

1 - Design

PHANTOM 4X is composed of a 3 axis positioning system and a large and stiff board/plate to emulate dynamic trajectory with high accuracy.

An additional independent axis moves a tracer on a vertical axis.

The plate/ board supporting the phantom is radioparent (carbon fiber / epoxy).

The device is fixed to the support thanks to 2 clamping systems with elastomeric interface in order to avoid any damage on the carbon tables of the imaging devices.

A dedicated trolley integrating the electronic control unit can store the device at ergonomic height and allows a great mobility of the set.

Examples of supported phantoms

- IEC standard Phantom (body and head)
- Pelvis phantom (PELVIS BRAINLAB)
- OCTAVUS
- OCTAVUS 4D with matrix
- SUN NUCLEAR ArcCHECK

The axes are simultaneously remotely controlled by PC via network cable. Input data format: points type file (.xls, .txt or .csv).

- Setpoint 0, coordinate X0, coordinate Y0, coordinate Z0
- Setpoint 1, coordinate X1, coordinate Y1, coordinate Z1
- Setpoint 2, coordinate X2, coordinate Y2, coordinate e Z2

2 - Applications

- Emulation of breathing movements.

3 - Datasheet

CHARACTERISTICS	VALUES
Stroke	
• X direction:	82 mm
• Y direction:	82 mm
• Z direction:	82 mm
• 4th axis Z2:	60mm
Maximal speed for each axis	15mm/s
Accuracy of dynamic positioning on each axis	0,2 mm
Carbon board thickness	5 mm
Load on Carbon board	35 kg max centered on the board
Load on platform (4th axis)	200 g
Device mass	60 kg
Power supply	220V single-phase

MONOPHAS2

4 - Dimensions

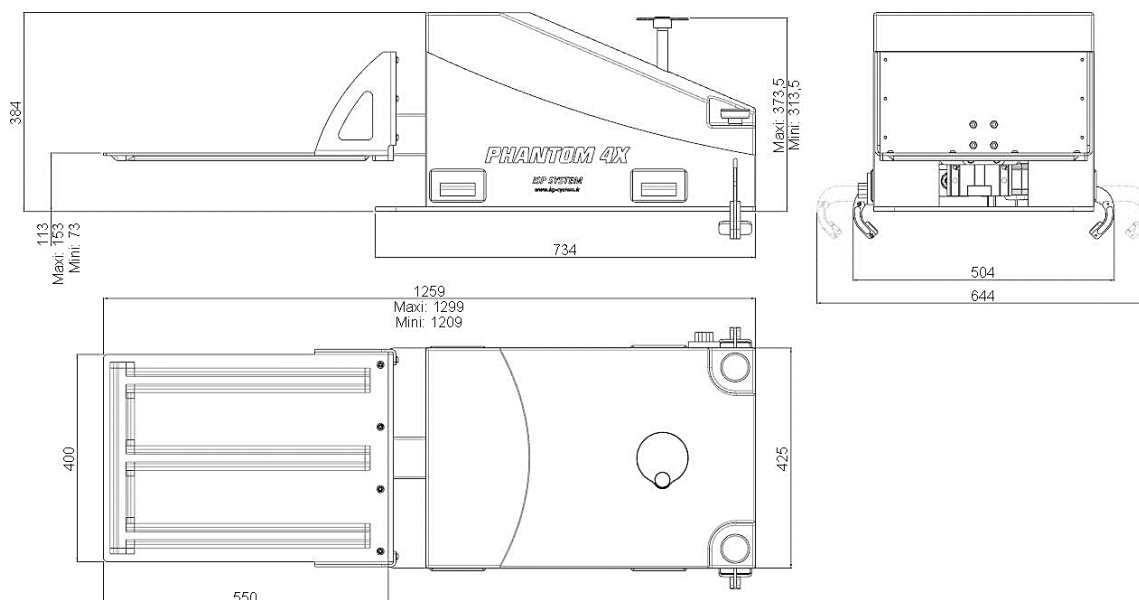

 **ISP SYSTEM**
Z.I. de la Herray
65500 VIC-EN-BIGORRE – France

 +33 (0)5 62 33 44 44
 contact@isp-system.fr

 www.isp-system.fr

Capital de 1 000 000 € - SIRET : 410 675 078 00027 – APE : 71128 – TVA : FR 19 410 675 078