

Update : 26/07/2013

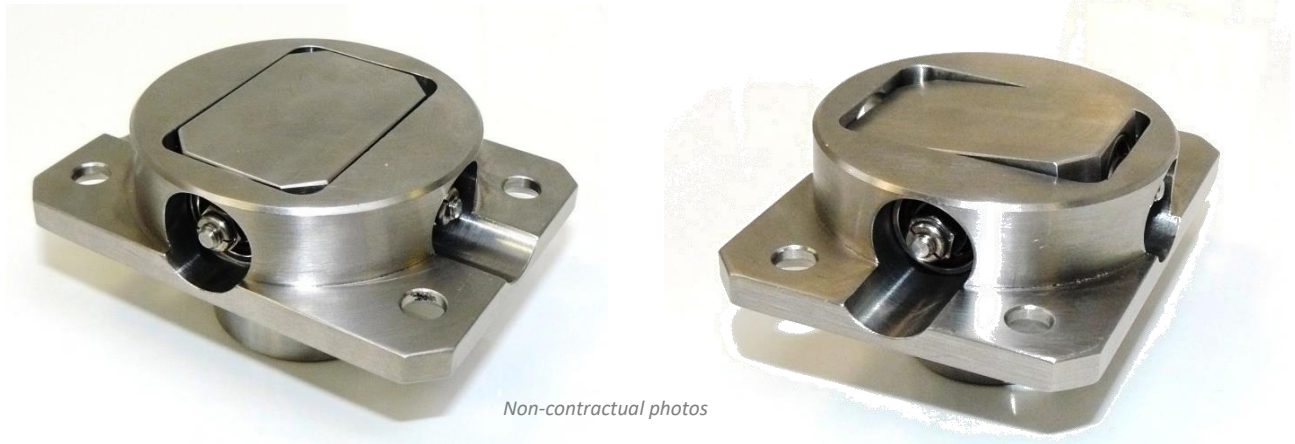

This ball joint mount, developed for our positioning stages, ensures the link with moved elements

1 - Description

Based on the principle of a coincidental link of a universal joint ball joint 3 pivot, they are manufactured thanks to 6 preloaded bearing and works without backlash.

The ball joint R350-50 has an excellent intrinsic mechanical aspect ensuring a support safety.

In case of extreme stress degrading the rolling components, the mechanical parts ensure as a chain link , a support of the component.

The ball joint are totally steel and are compatible clean room ISO6. Operation without maintenance.

An aluminum version is also available with reduced load. Characteristics, dimensions and interfaces can be adapted upon request.

High stiffness subject of the 3 motion axes.

2 - Characteristics : Range of movement

- θX and θY : +/- 3 degree
- θZ : 360 degree
- Stiffness as per X, Y and Z : 12 N/ μ m
- Load Maximum as per X, Y or Z : 350N, no Backlash
- Mass (version Stainless) : 500g

3 - Dimensions

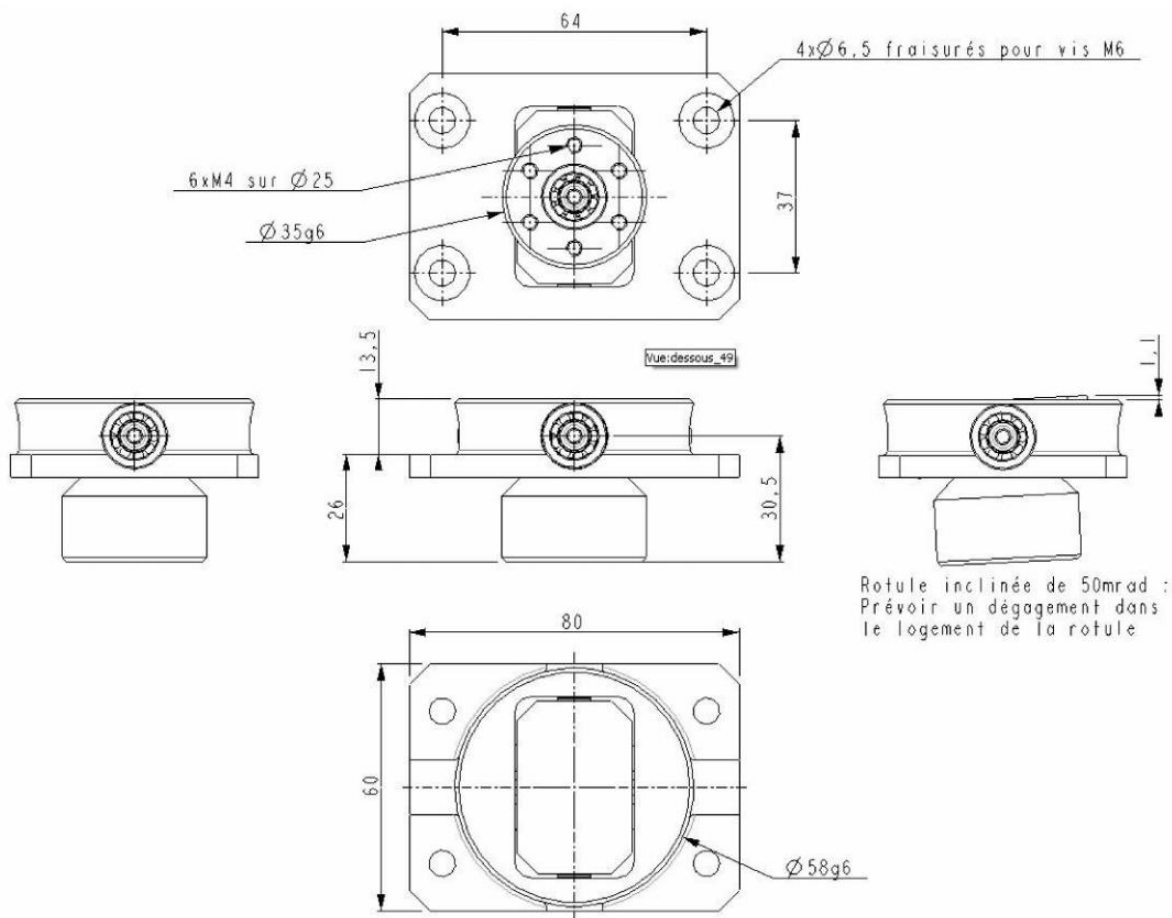

Nota: Technical data of this datasheet may be subject to modifications, depending on product updates.