

Update : 28/08/2013

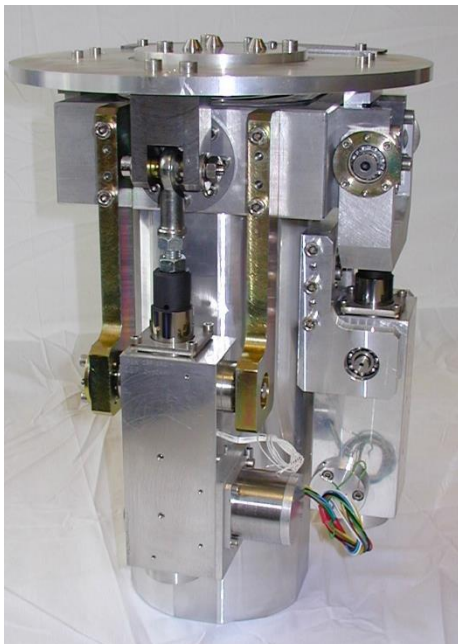

*Non-contractual photo*

**The positioner ensures high precision movement.**

It allows 3 adjustments as per  $\theta X$ ,  $\theta Y$  and  $\theta Z$ .

Fixed at the end of the support, the positioner allows you to orient the object according to the following principle:

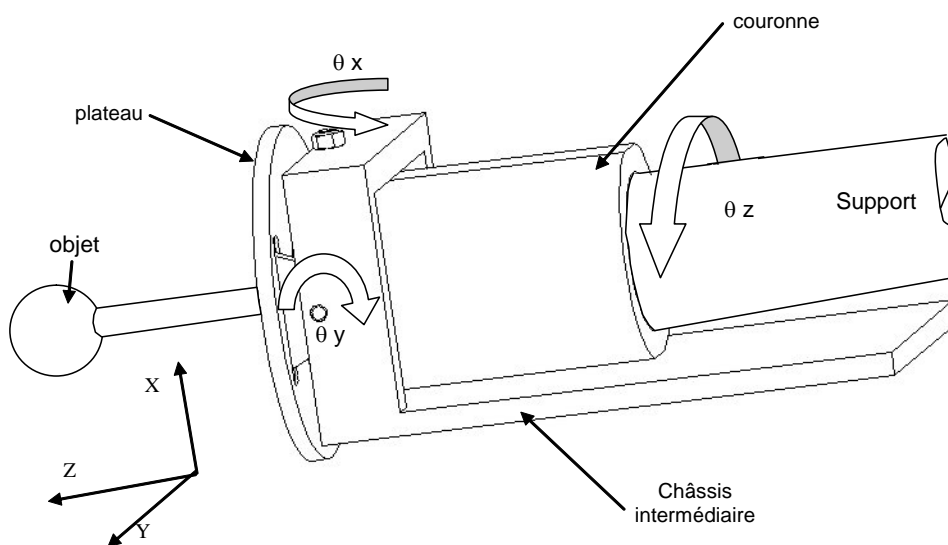

## 1 - Description

### The positioner includes:

- 2 steering actuators ( $\theta_x$  and  $\theta_y$ )
- 1 rotation actuator ( $\theta_z$ )

### Consists of:

- A ring gear which swivel on  $\varnothing 90$  mm tube for the movement around the axle Z
- A universal joint mounting
- An intermediary stirrup articulated on the ring gear and allowing motion around the axle X
- An articulated board on the intermediary and allowing motion around the axle Y

### Direction:

Each of the 2 steering actuators  $\theta_x$  and  $\theta_y$  consists of linear guidance system, as trail driven by screw and nut at ball prestressed.

## 2 - Technical specifications

CHARACTERISTICS	VALUES	
<b>Travel</b>	$\theta_x$ and $\theta_y$	$\pm 5^\circ$
	$\theta_z$	$\pm 5^\circ$
<b>Resolution</b>	50 $\mu$ rad	
<b>Precision</b>	$\pm 50$ $\mu$ rad	

- The structural parts are on aluminum
- The motorizations are type hybrid and bipolar stepper
- The axles has end of travel usually closed
- Mass of the product: 20 kg maxi to 400 mm of the ball joint axle
- Mass of the positioned: 49, 3 Kg

## 3 - Options

**CL xxxx** : Packaged for operation on cleanliness class (specify : 10, 100, 1000, 10 000)

**VS**: Adjustable to a vacuum of 10-6mbar operation.

*Nota: Technical data of this datasheet may be subject to modifications, depending on product updates.*

 **ISP SYSTEM**  
Z.I. de la Herray – B.P. 10047  
65501 VIC-EN-BIGORRE - France

 +33 (0)5 62 33 44 44

 [contact@isp-system.fr](mailto:contact@isp-system.fr)

 +33 (0)5 62 33 44 45

 [www.isp-system.fr](http://www.isp-system.fr)

Capital de 1 000 000 € - SIRET : 410 675 078 00027 – APE : 7112B – TVA : FR 19 410 675 078