

Update : 01/02/2019

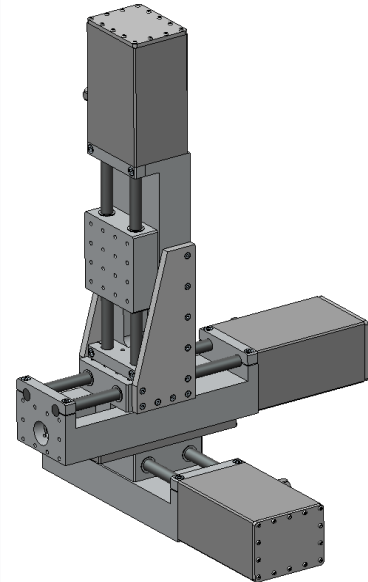
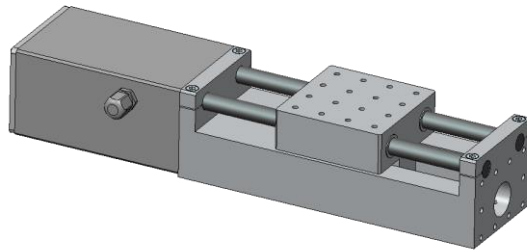

Non contractual photos

Positioning stage for use in aggressive environment

1 - Product description

Mechanical performances :

- Stroke : 150 mm
- Translation Speed : 5mm/s
- Encoder Resolution : 0,5µm/pt

Loading Capacity :

- Vertical Stage : 100 N
- Horizontal Stage : 400 N

2 - Technical data

- Movement by ball screw
- Translation guiding by linear bearing
- Magnetic absolute encoder on command axis (without clearance)
- DC Motor 12V to 48V
- Possible modification of stroke, speed, resolution
- Mass : 10 kg
- Mounting possibility XY or XYZ
- Working temperature : -10°C to +80°C
- Sealing IP68

3 - Dimension : (plan)

