

Update : 01/02/2019

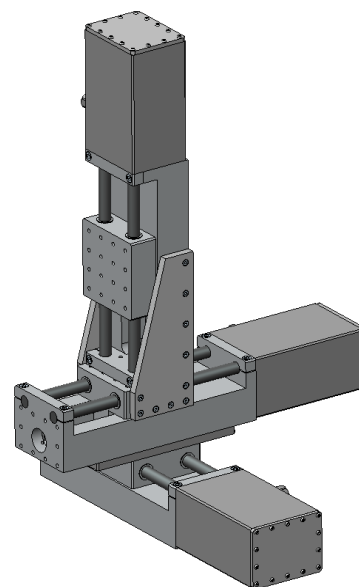
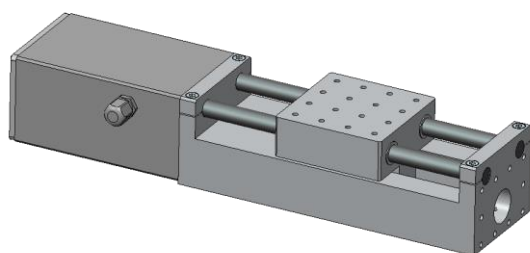

*Non contractual photos*

**Positioning stage for use in aggressive environment**

## 1 - Product description

### Mechanical performances :

- Stroke : 150 mm
- Translation Speed : 5mm/s
- Encoder Resolution : 0,5µm/pt

### Loading Capacity :

- Vertical Stage : 100 N
- Horizontal Stage : 400 N

## 2 - Technical data

- Movement by ball screw
- Translation guiding by linear bearing
- Magnetic absolute encoder on command axis (without clearance)
- DC Motor 12V to 48V
- Possible modification of stroke, speed, resolution
- Mass : 10 kg
- Mounting possibility XY or XYZ
- Working temperature : -10°C to +80°C
- Sealing IP68

**3 - Dimension : (plan)**

